

Storage & Material Handling

Greenlee storage systems protect the tools you've invested in and use day in and day out. From our smallest chests to our large field office, our storage boxes are as tough as the trade. With our patented, dual-recessed lock enclosures, you'll prevent theft. And newly-designed ergonomic features make Greenlee's storage and handling systems easy to use and easy to move around the jobsite.

Contents

Chests	410
Slant Top Boxes	411
Flat Top Boxes	412
Utility Cabinets	413
Mobile Workbench	415
Welder's Boxes	415
Field Office	416
Casters	417
Wire And Cable Handling	418
Caddys	418
Carts	421
Dispensers	424
Stands	425
Reel Rollers	426



GREENLEE®
A Textron Company

MADE FOR THE TRADE!™



STORAGE

Chests

Storage & Handling



1332



2448



2460

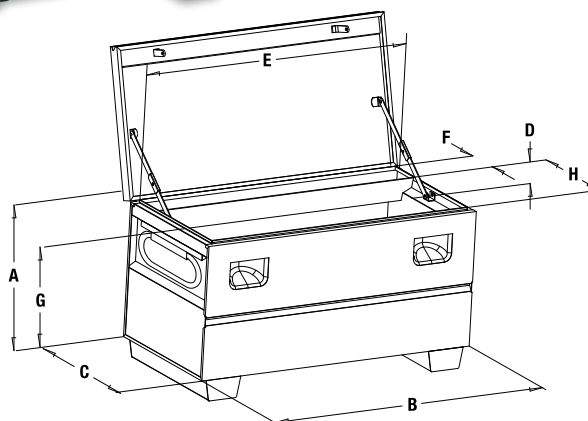

- Recessed and concealed lock protectors for maximum security against drilling and cutting lock. (Model 1332 one lock protector only.)
- Enhanced lid bolster for added support and durability.
- Finger-groove lid handle for easy opening.
- Convenient storage tray on back wall for small items (except Models 1332, 1636 and 2142).
- Steel support arm(s) to hold lid in open position.
- Heavy-duty piano hinges with non-removable pin.
- Patented, ergonomically designed fold-down recessed handles.
- New angled 3-1/2" high support skids feature threaded holes for easy caster installation.
- Recommend #1 and #5 Masterlock padlocks or equivalent.



Optional casters available for increased mobility.
See page 368 for options

CAT. NO.	UPC NO.	CAPACITY FT ³	DIMENSIONS								WEIGHT	
			A	B	C	D	E	F	G	H	LBS.	kg
1332	38717	4.9	14"	32"	19"	—	29.5"	—	—	14.5"	78	35
1636	38718	6.7	17"	36"	19"	—	33.5"	—	—	14.5"	101	46
2142	31651	9.7	20"	42"	20"	—	39.5"	—	—	15.5"	124	56
2448	23273	16	25"	48"	24"	4"	45.5"	4"	17.5"	15.5"	159	72
2460	23363	20	25"	60"	24"	4"	57.5"	4"	17.5"	15.5"	184	83
3048	23362	25	30"	48"	30"	4"	45.5"	4"	23.5"	21.5"	200	91
2472	07483	24	25"	72"	24"	4"	69.5"	4"	17.5"	15.5"	214	97

INTERNATIONAL

Tel: +1.815.397.7070
Fax: +1.815.397.9247

CANADA

Tel: 800.435.0786
Fax: 800.524.2853

USA

Tel: 800.435.0786
Fax: 800.451.2632

Slant-Top Boxes



3660



2260



3648



Hinged Lower Shelf

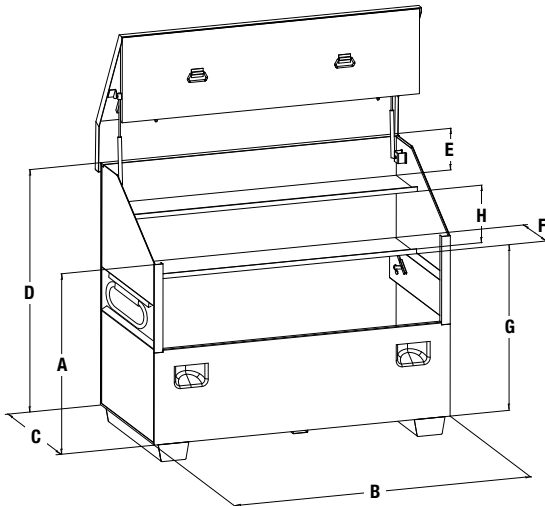

- Large capacity storage with traditional slant-top design.
- Recessed and concealed lock protectors provide maximum security against drilling and cutting locks.
- Channel reinforcements on lid, lock side panels into lid for added security when closed.
- Hinged lower shelf enables storage of larger items.
- Hemmed (reinforced) high-strength shelves.
- Continuous, non-removable hinge pins help prevent theft.
- Strategically located, easily accessible, durable gas-shocks provide for ease in opening lid (except Model 2260).
- New angled 3-1/2" high support skids feature threaded holes for easy caster installation.
- Angled handle recess prevents pinch points.
- Features two reinforced steel shelves with large lip to prevent items from rolling off (Model 2260, one shelf only).
- Double-hinged cover on Models 3648 and 3660 folds up and out of the way.
- Model 2260 comes with lid support to form waist-high, flat work area.
- Patented, ergonomically designed fold-down recessed handles.
- Recommend #1 and #5 Masterlock padlocks or equivalent.

CAT. NO.	UPC NO.	CAPACITY		DIMENSIONS							WEIGHT		
		FT ³		A	B	C	D	E	F	G	H	LBS.	kg
2260	23270	32		22"	60"	32"	36"	12"	12"	21"	—	273	124
3648	23276	34		36"	48"	30"	48"	5"	12"	27"	11"	270	123
3660	23196	44		36"	60"	30"	48"	5"	12"	27"	11"	314	142

N = NEW PRODUCT **R** = REPLACEMENT PART **A** = ACCESSORY



Optional casters available for increased mobility. See page 368 for options

Storage & Handling

USA

Tel: 800.435.0786
Fax: 800.451.2632

CANADA

Tel: 800.435.0786
Fax: 800.524.2853

INTERNATIONAL

Tel: +1.815.397.7070
Fax: +1.815.397.9247



Flat-Top Boxes

Storage & Handling



3360



4848



4860



4872



Hinged Lower Shelf

- Flat-top design provides more storage capacity for tall, bulky items, plus a large work surface for jobsite plans.
- Recessed and concealed lock protector inhibits forced entry and corrosion to lock.
- Channel reinforcements on lid, lock side panels into lid for added security when closed.
- Hinged lower shelf allows for easy storage of larger objects (except Model 3360).
- Angled handle recess prevents pinch points.
- Hemmed (reinforced) high-strength shelves.
- Continuous, non-removable hinge pins help prevent theft.
- Side-wall storage (except Model 3360).
- Strategically located, easily accessible, durable gas springs provide for ease in opening lid.
- Double hinge cover folds up and out of the way.
- New angled 3-1/2" high support skids feature threaded holes for easy caster installation.
- Patented, ergonomically designed fold-down recessed handles.
- Recommend #1 and #5 Masterlock padlocks or equivalent.

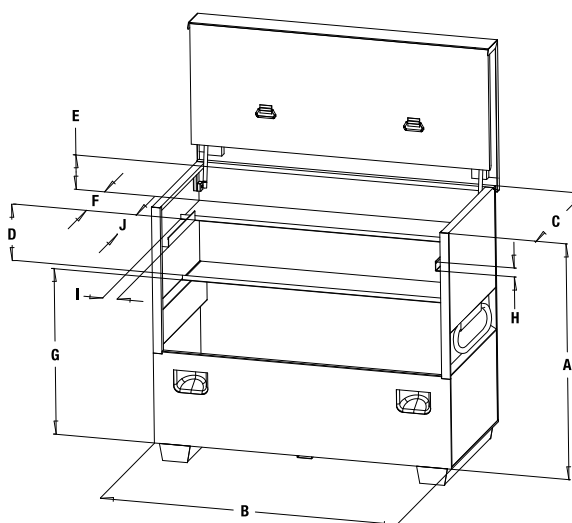

Optional casters available for increased mobility. See page 368 for options

CAT. NO.	UPC NO.	CAPACITY FT ³	DIMENSIONS										WEIGHT	
			A	B	C	D	E	F	G	H	I	J	LBS	kg
3360	38719	34.5	33"	60"	30"	—	12.5"	12"	20"	—	—	—	256	116
4848	35043	40	48"	48"	30"	11"	7"	12"	27"	2"	3"	17"	283	128
4860	35057	50	48"	60"	30"	11"	7"	12"	27"	2"	3"	17"	358	162
4872	07487	60	48"	72"	30"	11"	7"	12"	27"	2"	3"	17"	373	169

INTERNATIONAL

Tel: +1.815.397.7070
Fax: +1.815.397.9247

CANADA

Tel: 800.435.0786
Fax: 800.524.2853

USA

Tel: 800.435.0786
Fax: 800.451.2632

Utility Cabinets

2-DOOR UTILITY CABINET



5660L

HALF-STORAGE/HALF CABINET BOX



5660LH

2-DOOR, 30" DEPTH STORAGE CABINET



5760TD

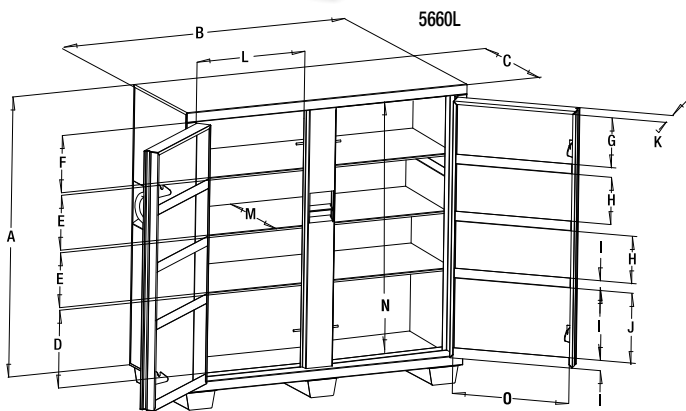

Optional casters available for increased mobility. See page 368 for options

- Recessed and concealed lock protector inhibits forced entry and corrosion to lock.
- Flush-mounted doors.
- Finger-groove door handles.
- Front-door storage.
- Hemmed (reinforced) high-strength shelves.
- Large, lower storage areas for bigger items.
- Continuous, non-removable hinge pins to prevent theft.
- New angled 3-1/2" high support skids feature threaded holes for easy caster installation.
- Three 3-1/2" high support skids.
- Weather-resistant design.
- Open storage for shovels, picks, brooms and other long-handled tools. (Model 5660LH only.)
- Patented, ergonomically designed fold-down recessed handles.
- Recommend #1 and #5 Masterlock padlocks or equivalent.

CAT. NO.	UPC NO.	CAPACITY FT ³	DIMENSIONS													WEIGHT			
			A	B	C	D	E	F	G	H	I	J	K	L	M	N	O	LBS.	kg
5660L	38659	46	56"	60"	24"	15"	10.5"	11.5"	10"	10"	2"	14"	3"	23.5"	20.5"	50.5"	24"	389	176
5660LH	07486	46	56"	60"	24"	15"	10.5"	11.5"	10"	10"	2"	14"	3"	23.5"	20.5"	50.5"	24"	375	170
5760TD	07969	59.3	56"	60"	30"	15"	10.5"	11.5"	10"	10"	2"	14"	3"	23.5"	26.5"	50.5"	24"	441	200

N = NEW PRODUCT **R** = REPLACEMENT PART **A** = ACCESSORY

Storage & Handling

USA

Tel: 800.435.0786
Fax: 800.451.2632

CANADA

Tel: 800.435.0786
Fax: 800.524.2853

INTERNATIONAL

Tel: +1.815.397.7070
Fax: +1.815.397.9247



Mesh Cabinet



5060MESH

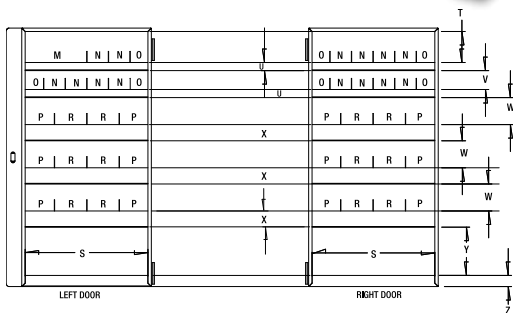

- High-visibility mesh screen on three (3) sides.
- Forty-eight (48) smaller, individual compartments, enabling storage of smaller tools and accessories.
- Platform for shovels, picks, brooms and other long-handle tools.
- Sturdy handle for mobility.
- Supplied with two (2) swivel casters and two (2) rigid 4" (102 mm) casters for easy mobility (Model 696).
- Recommend #1 and #5 Masterlock padlocks or equivalent.

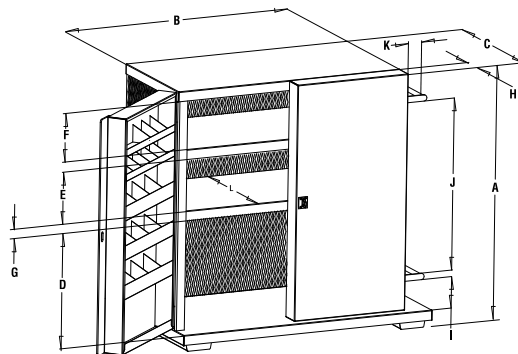

Included

CAT. NO.	UPC NO.	CAPACITY FT ³	DIMENSIONS																				WEIGHT						
			A	B	C	D	E	F	G	H	I	J	K	L	M	N	O	P	R	S	T	U	V	W	X	Y	Z	LBS.	kg
5060MESH	04460	37.3	52"	48"	28"	22"	10.5"	10"	2"	4"	5"	35"	5.5"	23"	11.5"	4"	3"	5.5"	6"	23"	5.5"	1.5"	3.5"	5"	3"	9"	2"	401	182

Bi-Fold Cabinet



5860

- Maximum storage capacity with minimum floor space requirements.
- Four (4) individual 15" d. x 14-1/2" h. x 60" w. (381 x 368 x 1524 mm) storage compartments on each side.
- Reinforced steel shelves welded in place for added strength and durability.
- All shelves feature large front lip to keep small items from rolling off.
- Each bi-fold section is mounted on four casters for easy opening and closing.
- Six (6) swivel and two (2) rigid 6" (152 mm) casters included for easy mobility (Models 503 and 603).
- Recommend #1 and #5 Masterlock padlocks or equivalent.

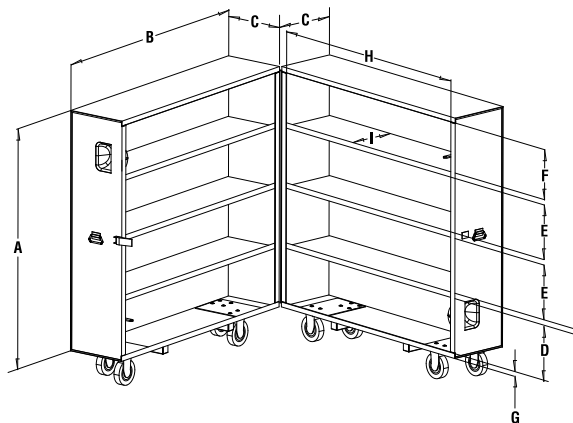

Included

CAT. NO.	UPC NO.	CAPACITY FT ³	DIMENSIONS									WEIGHT	
			A	B	C	D	E	F	G	H	I	LBS.	kg
5860	35068	60.4	58"	60"	15"	13"	13"	12"	1"	57"	14.5"	549	249

Mobile Workbench



- Tough composition board work surface on top with built-in chain vise and telescoping wrench stop.
- Removable self-stored shelf enables storage of larger items.
- Supplied with two (2) locking swivel casters and two (2) rigid 6" (152 mm) casters for easy mobility (Model 703).
- Recessed and concealed lock protector inhibits forced entry and corrosion to lock.
- Flush-mounted doors.
- Finger-groove door handles.
- Front door storage.
- Hemmed (reinforced) high-strength shelves.
- Large lower storage areas for bigger items.
- Continuous, non-removable hinge pins to prevent theft.
- Angled handle recess to prevent pinch points.
- Patented, ergonomically designed fold-down recessed handles.
- Recommend #1 and #5 Masterlock padlocks or equivalent.

3548

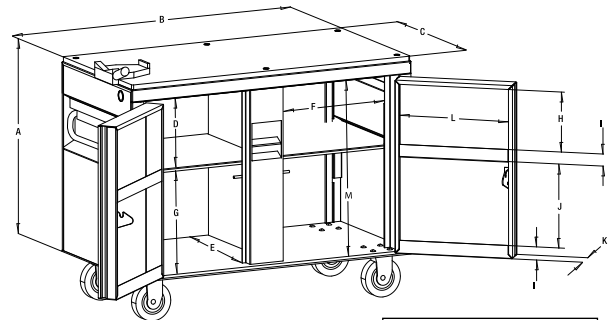

CAT. NO.	UPC NO.	CAPACITY FT ³	DIMENSIONS											WEIGHT			
			A	B	C	D	E	F	G	H	I	J	K	L	M	LBS.	kg
3548	31229	20	30"	48"	24"	11"	20.5"	17.5"	15"	9.5"	2"	13"	3"	17"	27"	293	133



Included

Welder's Boxes

1230



1531



- Protects small tools and supplies.
Single lock hasp for use with padlock.
- Compact side handles for easy portability.
- Heavy-duty hinges, plus chain connector to hold lid in open position.
- Recommend #1 and #5 Masterlock padlocks or equivalent.

CAT. NO.	UPC NO.	CAPACITY FT ³	DIMENSIONS			WEIGHT	
			HEIGHT	WIDTH	DEPTH	LBS.	kg
1230	31510	3.3	12"	30"	16"	42	19
1531	23274	4.8	15"	31"	18"	52	24

N = NEW PRODUCT **R** = REPLACEMENT PART **A** = ACCESSORY

Storage & Handling

USA

Tel: 800.435.0786
Fax: 800.451.2632

CANADA

Tel: 800.435.0786
Fax: 800.524.2853

INTERNATIONAL

Tel: +1.815.397.7070
Fax: +1.815.397.9247



Field Office

Storage & Handling

INTERNATIONAL

Tel: +1.815.397.7070
Fax: +1.815.397.9247

CANADA

Tel: 800.435.0786
Fax: 800.524.2853

USA

Tel: 800.435.0786
Fax: 800.451.2632



8060 DLX

(Tools sold separately)



Tamper-proof lock protectors (for upper and lower doors).



Slanted work surface with lockable, concealed storage area.



Door grooves provide a gripping surface for convenient opening.



Top door opens with a gas spring and is supported by a locking arm.

- Slanted work surface with lockable, concealed storage area.
- Concealed lock protectors protect locks from drilling and cutting.
- Weather stripping on doors to help protect documents and tools from the elements.
- Lid with heavy-duty gas spring and a locking arm for ease of opening and safety.
- Shelving throughout, for organizing and storing jobsite tools and supplies.
- Grooved front doors for ease of opening and storage compartment access.
- Patented, ergonomically designed fold-down recessed handles.
- Continuous, non-removable pin hinges.
- Overlapping corners, rolled edges, and strategically placed reinforcements for added strength.
- Recommend #1 and #5 Masterlock padlocks or equivalent.
- Welded 16-gauge steel construction for durability.
- Transportable with forklift.
- Optional casters available for increased mobility.

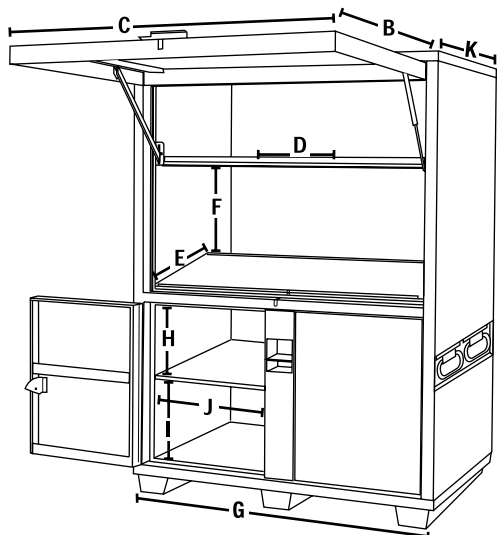

Optional casters available for increased mobility.
See page 368 for options

CAT. NO.	UPC NO.	CAPACITY		DIMENSIONS										WEIGHT		
		FT ³		A	B	C	D	E	F	G	H	I	J	K	LBS.	kg
8060 DLX	04719	116.5		80"	41.6"	55.6"	20.6"	26.8"	19.2"	60"	14"	15.5"	24"	42"	683	310

Casters

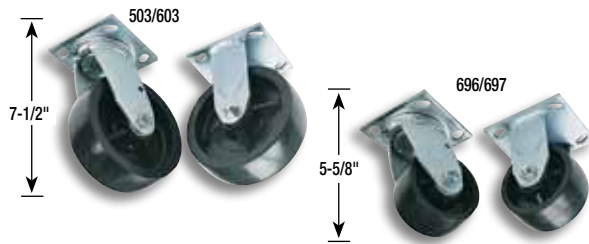

- Caster bolt pattern 2-7/8" x 3-1/4".
- Polyolefin-injected molded hard casters: stain-resistant, chemical-resistant, and non-marking.

CAT. NO.	UPC NO.	DESCRIPTION	WHEEL		CAPACITY		SHIP WEIGHT	
			DIA. IN. (mm)	TREAD IN. (mm)	LBS.	kg	LBS.	kg
503*	28044	4 Swivel	6 (152)	2 (51)	2000	907	22	10
603*	23405	2 Rigid, 2 Swivel	6 (152)	2 (51)	2000	907	20	9
703†	08420	2 Rigid, 2 Locking Swivel	6 (152)	2 (51)	2000	907	20	9
696*	15341	2 Rigid, 2 Swivel	4 (102)	2 (51)	1600	726	13	6
697*	89189	4 Swivel	4 (102)	2 (51)	1600	726	15	7

*Each caster set includes (16) 3/8-16 x 1" self-threading mounting screws.

†Each caster set includes (16) 3/8-16 x 1" carriage bolts; (16) 3/8-16 hex nuts; (16) 3/8 lockwashers.

Note: Screw/washer kit p/n 50062913 is necessary for mounting 703/803 casters on boxes other than 3548.

CASTER SELECTION CHART

STORAGE BOX CAT. NO.	503	603	703	696	697
1332	✓	✓		✓	✓
1636	✓	✓		✓	✓
2142	✓	✓		✓	✓
2448	✓	✓		✓	✓
2460	✓	✓		✓	✓
3048	✓	✓		✓	✓
2472	✓	✓		✓	✓
1230					
1531					
5060MESH	✓	✓		Included	✓
3360	✓	✓		✓	✓
4848	✓	✓		✓	✓
4860	✓	✓		✓	✓
4872	✓	✓		✓	✓
2260	✓	✓		✓	✓
3648	✓	✓		✓	✓
3660	✓	✓		✓	✓
5660L	✓	✓		✓	✓
5660LH	✓	✓		✓	✓
5760TD	✓	✓		✓	✓
5860	Included	Included			
3548	✓	✓	Included		
8060DLX	✓	✓		✓	✓

Replacement Parts

REPLACEMENT PARTS

CAT. NO.	UPC NO.	DESCRIPTION
06291	06291	Box Caster Bolt Set (16-Bolt Kit)
08426	08426	Box Caster Bolt Set 16-Bolt Kit (3548, 5860 only)
52025978	20965	Lid Support – (L) Side
52025979	20966	Lid Support – (R) Side
08428	08428	10 mm Gas Spring Ball Stud Replacement Kit (all Slant/Flat-Tops)
53950	53950	Gas Springs for 2260
53904	53904	Gas Springs for 3360, 4848 and 4860 Storage Boxes
53951	53951	Gas Springs for 3648 and 3660
04339	04339	Latch Repair Kit (5860)
54997	54997	Latch (5860)
54998	54998	Strike (5860)
55124	55124	Latch Threaded Rod (5860)
08427	08427	13 mm Gas Spring Ball Stud Replacement Kit (8060 DLX)
55294	55294	Replacement Gas Spring Kit – Shock and (2) Clips (8060 DLX)
01886	01886	Replacement Gas Spring Kit for 4872

Greenlee Green Spray Touch-up Paint



- Closely matches Greenlee painted products.

CAT. NO.	UPC NO.	DESCRIPTION	WEIGHT	
			LBS.	kg
22618	22618	13 oz. (384 ml) Aerosol Can of Greenlee Green Spray Paint	1.2	.5
10378	10378	13 oz. (384 ml) Aerosol Can of Greenlee Flat Green Spray Paint*	1.2	.5

NOTE: The color green is a registered trademark for Test Instruments, Job Boxes, Benders and Pulling Equipment.
*For Storage Boxes

Storage & Handling

USA

Tel: 800.435.0786
Fax: 800.451.2632

CANADA

Tel: 800.435.0786
Fax: 800.524.2853

INTERNATIONAL

Tel: +1.815.397.7070
Fax: +1.815.397.9247



WIRE AND CABLE HANDLING

Folding Hand Caddy



- Holds up to 6 spools of #10 wire.
- Folds down to 2-1/2" (63.5 mm) for easy storage.
- Pinless design eliminates loose parts.

CAT. NO.	UPC NO.	DESCRIPTION
9501	01202	Folding Hand Caddy

SPECIFICATIONS

Size	10" (254 mm) H x 18-1/2" (470 mm) W
Capacity	Six 500' (152.4 m) spools of #10 AWG Maximum Spool Diameter: 7.5" (190 mm) Maximum Spool Diameter (top spindle, with empty bottom spindle): 12.5" (317 mm) Maximum Spool Width: 8.5" (215 mm)
Weight	5 lbs. (2 kg)

Hand Caddy

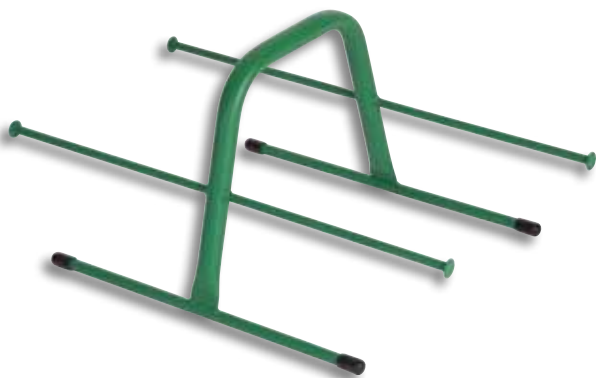

- Holds four 500' (152.4 m) spools of #10 AWG (7" dia. by 6"-10" wide)
- Holds up to eight 500' (152.4 m) spools of #12 AWG (7" dia. x 5" wide)
- 3/8" (9.5 mm) diameter solid steel spool support spindles.
- Spool retaining washers on spindles.
- Pinless design eliminates loose parts.

CAT. NO.	UPC NO.	DESCRIPTION
9502	08187	Hand Caddy

SPECIFICATIONS

Size	10-1/2" (267 mm) H x 14" (356 mm) W x 22.5" (572 mm) L
Capacity	Eight 500' (152.4 m) spools of #12 AWG; Four 500' (152.4 m) spools of #10 AWG Maximum Spool Diameter: 9" (229 mm) Maximum Spool Width: 10.5" (266 mm)
Weight	5 lbs. (2 kg)

Data Cable Caddy



- Width is ideal for large diameter spools of coax, data and communications cable.
- Especially handy for 6" (152 mm) wide and up to 19" (483 mm) diameter spools.
- Folds down for easy storage.
- Pinless design eliminates loose parts.

CAT. NO.	UPC NO.	DESCRIPTION
9520	01228	Data Cable Caddy

SPECIFICATIONS

Size	21" (533 mm) L x 28-1/2" (724 mm) W x 11-1/2" (292 mm) H
Capacity	Maximum Total Spool Weight: 100 lbs. (45 kg) Maximum Spool Diameter: 19" (483 mm) Maximum Spool Width: 24.50" (622 mm)
Weight	11 lbs. (5 kg)

Wire Reel Support Frame



(2 Shown)

- 914 consists of one frame with 2 wheels only; 2 or more 914's and a spindle made of 1" rigid conduit are required to make a reel support setup.
- Easy to set up. Insert spindle in one 914 support frame, tighten locking screw, slide reels on spindle, insert spindle in second 914 support frame, tighten thumb screw and you're ready to go.
- Casters swivel and lock for ease of use.

CAT. NO.	UPC NO.	DESCRIPTION
914	26438	Wire Reel Support Frame

SPECIFICATIONS

Size	17-1/2" (444 mm) W x 14" (355 mm) H
Capacity	1" Rigid Conduit for spindle; hold 500' (152.4 m) to 2500' (762 m) spools up to 18" (457 mm) in diameter
Weight	8.4 lbs. (3.8 kg)

Deluxe Wire Caddy



- All welded steel frame.
- 6 wire spool axles with spring clip locks.
- Collapsible wire guide.
- Swivel caster set with two (2) locking casters for easy use.

CAT. NO.	UPC NO.	DESCRIPTION
906	33026	Wire Caddy with Casters and Wire Guide
33405	33405 R	Caster Set (2 swivel, 2 swivel lock)
50303	50303 R	Hitch Clip

SPECIFICATIONS

Size	16" (406 mm) L x 26" (660 mm) W x 17-1/2" (444 mm) H
Capacity	Six 500' (152 m) spools up to 8" (203 mm) in diameter of #6 thru #10 AWG Maximum Spool Width: 2 x 8.5" (215 mm), 4 x 12.13" (308 mm)
Weight	14.8 lbs. (6.7 kg)

6-Spindle Wire Caddy



- All steel welded frame with 6 reel spindles and feeding eye.
- Angled spindles keep reels in place without locks and help brake the reel while paying out.
- Mobile, two (2) fixed wheels and one (1) that swivels and locks, allow easy movement and control.
- Fits through a 30" (762 mm) doorway.

CAT. NO.	UPC NO.	DESCRIPTION
909	22875	Wire Dispenser
52284	52284 R	Swivel Caster (1)
52285	52285 R	Wheel (2)

SPECIFICATIONS

Size	39" (990 mm) L x 30" (762 mm) W x 31" (787 mm) H.
Capacity	Six 2,500' (762 m) spools up to 18" (457 mm) in diameter. Maximum Spool Width: 13" (330 mm)
Weight	88 lbs. (40 kg)



6-Reel Caddy



- Spindle sleeves to facilitate easier pay-out of wire.
- Holds up to six (6) 2,500' (762 m) spools of #14, #12, or #10 AWG wire.
- Folds for easy storage.
- Two (2) fixed and two (2) locking swivel casters for easy portability.
- Pinless design eliminates loose parts.

CAT. NO.	UPC NO.	DESCRIPTION
9517	01225	6-Reel Caddy
01221	01221	Replacement Caster
01220	01220	Replacement Wheel

SPECIFICATIONS

Size	41" (1041 mm) H x 32" (813 mm) W
Capacity	Six (6) 2500' (762 m) spools of #10 AWG wire Maximum Total Spool Weight: 450 lbs. (204 kg) Maximum Spool Diameter: 15" (380 mm) Maximum Spool Width: 14.75" (375 mm)
Weight	75 lbs. (34 kg)

10-Reel Caddy



- Spindle sleeves to facilitate easier pay-out of wire.
- Holds up to ten (10) 2,500' (762 m) spools of #10 AWG wire.
- Folds down for easy storage.
- Two (2) fixed and two (2) locking swivel casters for easy portability.
- Pinless design eliminates loose parts.

CAT. NO.	UPC NO.	DESCRIPTION
9516	01222	10-Reel Caddy
01221	01221	Replacement Caster
01220	01220	Replacement Wheel

SPECIFICATIONS

Size	48" (1219 mm) H x 32" (813 mm) W
Capacity	Maximum Total Spool Quantity - Ten (10) 2500' (762 m) spools of #10 AWG wire Maximum Total Spool Weight: 750 lbs. (340 kg) Maximum Spool Diameter: 15" (380 mm) Maximum Spool Width: 14.63" (370 mm)
Weight	101 lbs. (46 kg)

Wire Dispenser

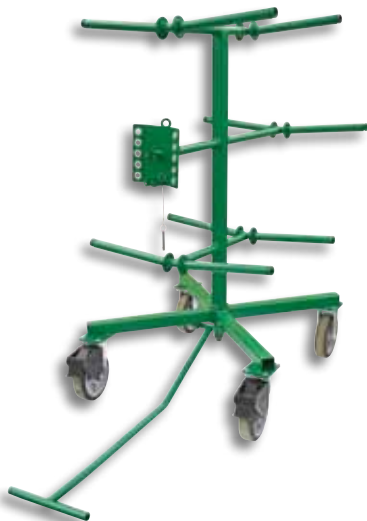

- All welded steel construction.
- Includes two (2) fixed and two (2) swivel locking heavy-duty casters.
- The spool rack consists of ten (10) spindles and an adjustable guide loop, and can be turned 360° independent of the base.
- Spindles are angled to contain reels and act as a brake while paying out wire.
- Fits through a 36" (915 mm) opening.

CAT. NO.	UPC NO.	DESCRIPTION
910	21982	Wire Dispenser
51488	51488	Caster (Rigid)
53259	53259	Caster (Swivel)

SPECIFICATIONS

Size	36-1/4" (921 mm) L x 31-1/2" (800 mm) W x 59" (1499 mm) H.
Capacity	Ten (10) 2500' (762 m) spools up to 18" (457 mm) in diameter. Maximum Spool Width: 14.18" (360 mm)
Weight	196 lbs. (89 kg)

Hand Truck / Wire Cart



- Holds up to twelve (12) spools of #12 AWG wire or eight (8) spools of #10 AWG wire.
- 10" (254 mm) diameter pneumatic tires for jobsite portability.
- Pinless design eliminates loose parts.
- Four (4) solid steel 1/2" (13 mm) spindles included.
- Lay cart flat when dispensing wire. Upright for use as hand truck.

CAT. NO.	UPC NO.	DESCRIPTION
9505	01205	Hand Truck Caddy
01207	01207	R Spindle (9505/9510)

SPECIFICATIONS	
Size	48" (1219 mm) H x 28-1/4" (718 mm) W
Capacity	Maximum Total Spool Weight: 200 lbs (90.7 kg) 4000' (1219 m) # 10 AWG wire Maximum Spool Diameter: 7.5" (190 mm) Dolly Lift (Maximum): 250 lbs. (113 kg) Maximum Spool Width: 18" (457 mm)
Weight	32 lbs. (14 kg)

Deluxe A-Frame Wire Cart



- Holds up to twenty four (24) spools of #12 AWG wire or sixteen (16) spools of #10 AWG wire.
- Folds for easy storage.
- 10" (254 mm) diameter pneumatic tires for jobsite portability.
- Pinless design eliminates loose parts.
- Eight (8) solid steel 1/2" (12.7 mm) spindles included.
- Optional Basket Caddy available to dispense metal-clad cable (see page 363).

CAT. NO.	UPC NO.	DESCRIPTION
9510	01214	Deluxe A-Frame Mobile Caddy
01207	01207	R Spindle (9505/9510)

SPECIFICATIONS	
Size	48" (1219 mm) H x 28-1/4" (718 mm) W
Capacity	Maximum Total Spool Weight: 400 lbs. (181 kg) Maximum Spool Diameter: 7.5" (190 mm) Maximum Spool Width: 18" (457 mm)
Weight	47 lbs. (21 kg)

Storage & Handling

USA

Tel: 800.435.0786
Fax: 800.451.2632

CANADA

Tel: 800.435.0786
Fax: 800.524.2853

INTERNATIONAL

Tel: +1.815.397.7070
Fax: +1.815.397.9247



Hand Truck / Wire Cart



38733
With 10462 Expander Kit



38733

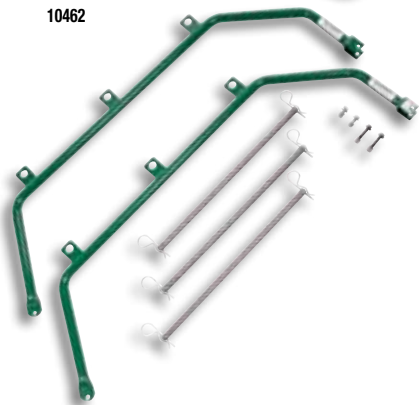

10462

- Heavy-duty wheels for durability and easy transporting.
- Dual heavy-duty wire guides for dispensing multiple wires in all directions.
- Only 23" (584 mm) wide to fit through narrow doorways.
- Comes with five 5/8" (16 mm) diameter reel spindles for storing and dispensing up to fifteen spools of #14 THHN wire.
- Storage space for three (3) spindles and clips eliminates loose parts when they are not in use.
- Expander kit available to increase capacity by 60%.

CAT. NO. UPC NO. DESCRIPTION

38733	38733	Hand Truck Wire Cart
10462	10462	A Expander Kit
50303	50303	B Hitch Clip
38774	38774	R Spindle (38733)

SPECIFICATIONS

Size	38733	46" (1168 mm) H x 23" (584 mm) W x 22-1/2" (571 mm) D
	10462	41" (1041 mm) H x 12-5/8" (321 mm) W
Weight	38733	58 lbs. (26 kg)
	10462	15.7 lbs. (7 kg)

WIRE CAPACITY CHART

NUMBER OF SPOOLS		MAXIMUM SPOOL DIAMETER	MAXIMUM SPOOL WIDTH	TYPICAL WIRE LENGTH
38733 WIRE CART	WITH 10462 EXPANDER			
15	24	7" (178 mm)	5-3/8" (137 mm)	500 ft. (152 m)
10	16	7" (178 mm)	8" (203 mm)	500 ft. (152 m)
3	5	12" (305 mm)	16-3/8" (416 mm)	2,500 ft. (762 m)
3	3	14" (356 mm)	16-3/8" (416 mm)	2,500 ft. (762 m)
2	2	22" (559 mm)	16-3/8" (416 mm)	1,000 ft. (305 m)

Wire Cart



- Large capacity, excellent for storing, transporting or feeding wire.
- Save space, use and store vertically or horizontally.
- Five (5) strong reel axles with spring clip retainers plus two (2) positions for axle storage allows you to configure for large reels with no loose parts.
- Strong, yet lightweight, tubular steel welded construction with rugged 8" (203 mm) wheels.
- Built-in wire guide for horizontal dispensing.
- Will pass through a 28" (711 mm) opening.

CAT. NO. UPC NO. DESCRIPTION

911	31518	Wire Cart
31523	31523	B Reel Shaft for 911 Wire Cart
50303	50303	B Hitch Clip

SPECIFICATIONS

Size	54-1/2" (1384 mm) L x 27" (685 mm) W x 26-1/2" (673 mm) H when horizontal
Capacity	Six (6) 2,500' (762 m) spools up to 16" (406 mm) in diameter Fifteen (15) 500' (152 m) spools up to 8" (203 mm) in diameter Max. Spool Weight: 550 lbs. Maximum Spool Width: 24" (610 mm)
Weight	62 lbs. (28 kg)

Cable Reel Transporter



- All steel welded frame with heavy-duty wheels.
- Unique design provides easy setup for cable payout.
- Handle folds to save space when using as a dispenser.

CAT. NO.	UPC NO.	DESCRIPTION
----------	---------	-------------

916	32935	Cable Reel Transporter
33035	33035	R Spindle for 916 Transporter
52466	52466	R Wheel Kit (2)

SPECIFICATIONS

Size	63" (1600 mm) L x 29-7/8" (759 mm) W x 26-3/4" (679 mm) H when horizontal
Capacity	Reels of cable or BX up to 20" (508 mm) W and 40" (1016 mm) in diameter maximum total reel weight 300 lbs. (136 kg)
Weight	110 lbs. (50 kg)

Conduit and Pipe Storage Rack



- 7 individual bins allow you to sort by size and type.
- Folds down for storage.
- No. 603 Casters included.

CAT. NO.	UPC NO.	DESCRIPTION
----------	---------	-------------

668	15343	Mobile Conduit and Pipe Rack with 603 casters
503	28044	A 6" (152 mm) Diameter Caster Set, 4 Swivel
603	23405	R 6" (152 mm) Diameter Caster Set, 2 Swivel and 2 Rigid

SPECIFICATIONS

Capacity	1000 lbs. (454 kg)
Dimensions	58-1/2" (1486 mm) long x 34" (864 mm) wide x 63-1/2" (1613 mm) high
Folded Down	58-1/2" (1486 mm) long x 34" (864 mm) wide x 19" (483 mm) high
Weight	113 lbs. (51 kg)

Pipe Cart



- Easy, one-person operation saves time and money.
- Move standard 20 ft. (6.1 m) lengths of pipe.
- Large 4.80" x 8" (122 mm x 203 mm) wheels with 4-ply pneumatic tires.
- Heavy-duty steel construction for long service life.

CAT. NO.	UPC NO.	DESCRIPTION
----------	---------	-------------

36745	36745	Pipe Cart
02182	02182	R Wheel Replacement Kit (1)

SPECIFICATIONS

Capacity	20" (508 mm) Diameter – 1000 lbs. (454 kg)
-----------------	--

Storage & Handling

USA

Tel: 800.435.0786
Fax: 800.451.2632

CANADA

Tel: 800.435.0786
Fax: 800.524.2853

INTERNATIONAL

Tel: +1.815.397.7070
Fax: +1.815.397.9247



BX-Armored Coiled Cable Dispenser



- Dispense armored cable, flexible conduit, Greenfield® or NM-B cable fast and easy without twists or tangles.
- Base with adjustable tension control rotates to dispense the cable without overpulling.
- Large pulling eye rotates freely and can be used as a carrying handle when the dispenser is empty.

CAT. NO.	UPC NO.	DESCRIPTION
37218	37218	Armored Cable Dispenser

SPECIFICATIONS

Size	13-1/2" (343 mm) H x 26" (660 mm) diameter
Capacity	One 250' (76 m) coil of 14/2, 14/3, 12/2, or 12/3 armored cable or romex.
Weight	32 lbs. (14 kg)

Armored Coiled Cable Dispenser/Transporter



- Dispense one (1) coil of armored cable, flexible conduit, Greenfield® or NM-B cable fast and easy without twists or tangles.
- Base with adjustable tension control rotates to dispense the cable without overpulling.
- Large pulling eye rotates freely.
- Transport up to three coils.

CAT. NO.	UPC NO.	DESCRIPTION
37202	37202	Armored Cable Dispenser/Transporter

SPECIFICATIONS

Size	45" (1143 mm) H x 28-1/2" (724 mm) W x 29" (736 mm) D
Capacity	Dispense - One 250' (76.2 m) coil of 14/2, 14/3, 12/2, or 12/3 armored cable or romex. Transport - Three (3) Coils, maximum capacity 250 lbs. (113 kg).
Weight	55 lbs. (25 kg)

Caddy Basket Cable Dispenser

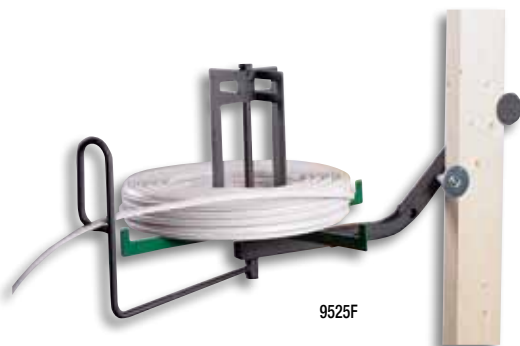

STUD MOUNT CADDY (9525F)

- Fits both 2x4 and 2x6 studs.
- Dispense coils of NM-B or armored cable.
- Swivel eyelet eliminates tangles.
- Add 9529F basket to double capacity.
- Folds for easy storage.

CAT. NO.	UPC NO.	DESCRIPTION
9525F	02070	Folding Stud Mount Caddy

SPECIFICATIONS

9525F	
Maximum Capacity	100 lbs. (45.4 kg)
Weight	10.5 lbs. (4.8 kg)
Size	29-1/2" (749 mm) H x 20-3/4" (527 mm) W

Hanging Cable Dispenser

NEW



- Hangs virtually anywhere
- Rugged aluminum, steel, and nylon construction
- Quick set-up and take down
- Collapses for easy storage
- Storage bag included

CAT. NO.	UPC NO.	DESCRIPTION
9522	12671	Hanging Cable Dispenser

SPECIFICATIONS

Length Set Up	37-1/2" (953 mm)
Width Set Up	23-1/2" (597 mm)
Capacity	250' of NM or MC cable up to 75 lb
Weight	3-1/2 lbs. (1.6 kg)

Screw-Type Reel Stands

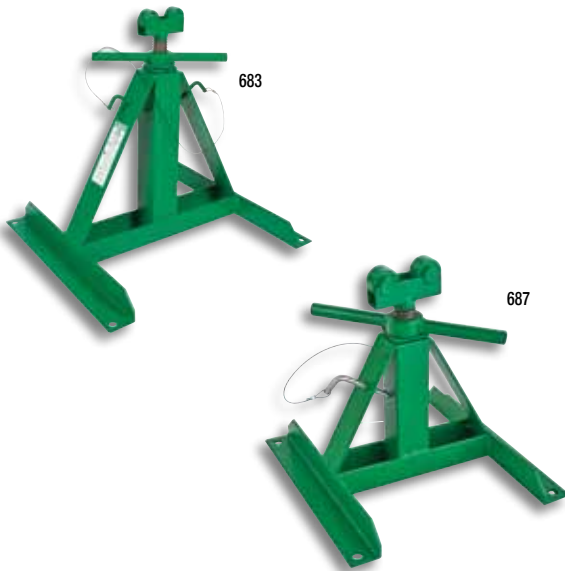

- Wide, welded steel base for added stability with 5/8" holes.
- Roller bearings fit in the spindle groove to keep the spindle in place and turning freely.
- Two stands and a spindle are required for a complete setup.

CAT. NO.	UPC NO.	DESCRIPTION
683	15372	Reel Stand 22" - 54" (559 - 1372 mm)
687	17076	Reel Stand 13" - 28" (330 - 711 mm)
684	15375	A Spindle for 683 Reel Stand
647	15321	A Spindle for 687 Reel Stand
25591	25591	B Stop Pin (683 - 2; 687 - 1)

SPECIFICATIONS

Size	683 - 24" x 21" (610 x 533 mm) base; 54" (1372 mm) maximum height 687 - 15" x 15" (381 x 381 mm) base; 28" (711 mm) maximum height
Capacity	683 - 2,500 lbs. (1134 kg) each, 46" - 96" (1168 x 2438 mm) reel diameter 687 - 2,500 lbs. (1134 kg) each, 28" - 56" (711 x 1422 mm) reel diameter
Weight	683 - 42 lbs. (19 kg) 687 - 22 lbs. (10 kg)

Ratchet-Type Reel Stand



- Ratchet mechanism to easily raise or lower the height.
- Roller bearings fit in the spindle groove to keep the spindle in place and turning freely.
- Two stands and a spindle are required for a complete setup.

CAT. NO.	UPC NO.	DESCRIPTION
656	21979	Ratchet Reel Stand 28" - 46-5/8" (711 mm - 1184 mm)
657	21980	A Spindle for 656 Reel Stand
30291	30291	R Handle with Grip

SPECIFICATIONS

Size	24-1/2" x 23" (622 mm x 584 mm) base; 46-5/8" (1184 mm) maximum height
Capacity	3,750 lbs. (1701 kg) each 58" - 90" (1473 mm - 2286 mm) reel diameter
Weight	87 lbs. (39 kg)



Reel Stand Spindles



CAT. NO.	UPC NO.	DESCRIPTION
647	15321	Spindle for 687 Reel Stand
657	21980	Spindle for 656 Reel Stand (only)
684	15375	Spindle for 683 Reel Stand

- Steel spindles with grooves to fit reel stand rollers.

SPECIFICATIONS

Size	647 - 2-3/8" diameter x 62" (60 x 1575 mm) 657 - 3-1/2" diameter x 100" (89 x 2540 mm) 684 - 2-3/8" diameter x 76" (60 x 1930 mm)
Capacity	647 - 5,000 lbs. (2268 kg) 59" (1500 mm) between grooves 657 - 7,500 lbs. (2388 kg) 94" (2540 mm) between grooves 684 - 5,000 lbs. (2268 kg) 73" (1854 mm) between grooves
Weight	647 - 42 lbs. (19 kg) 657 - 124 lbs. (56 kg) 684 - 50 lbs. (23 kg)

Reel Rollers

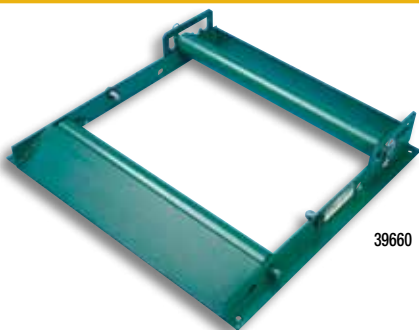

39660

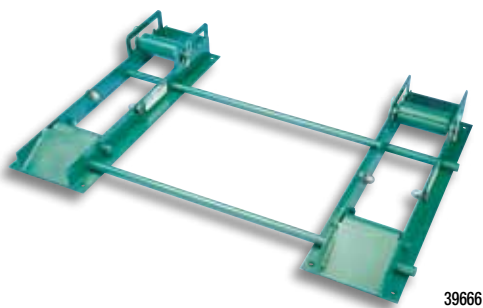

39666

- Heavy-duty welded steel construction.
- Built-in loading ramps.
- Adjustable to various reel widths and diameters. (21" dia. min.)
- Roller locks for unloading.
- Side ball rollers for centering.
- Fast, convenient ground-level setup for paying out large cable reels.

CAT. NO.	UPC NO.	DESCRIPTION
39660	39660	Reel Roller, single platform roller
39661	39661	Reel Roller, single (two required)
39664	39664	Spreader Kit, two 48" spreader bars
39666	39666	Reel Roller Kit, (includes two 39661 rollers and one 39664 spreader kit)

SPECIFICATIONS

Size	39660 - 32" (813 mm) L x 34" (864 mm) W, 87 lbs. (39 kg) 39661 - 32" (813 mm) L x 11" (279 mm) W, 45 lbs. (20 kg) 39664 - 48" (1067 mm) L, 9 lbs. (4 kg) 39666 - 32" (813 mm) L x 48" (1219 mm) W, 99 lbs. (45 kg)
Capacity	39660 - 2,500 lbs. (1134 kg) 30" (762 mm) max reel width 39661 - 2,000 lbs. (902 kg) per pair, 42" (1067 mm) max reel width 39666 - 2,000 lbs. (902 kg) 42" (1067 mm) max reel width